

The information contained in this drawing is the sole property of Coil Winding Specialist, Inc. www.coilws.com
Any reproduction in part or whole without written permission of Coil Winding Specialist, Inc. is prohibited.

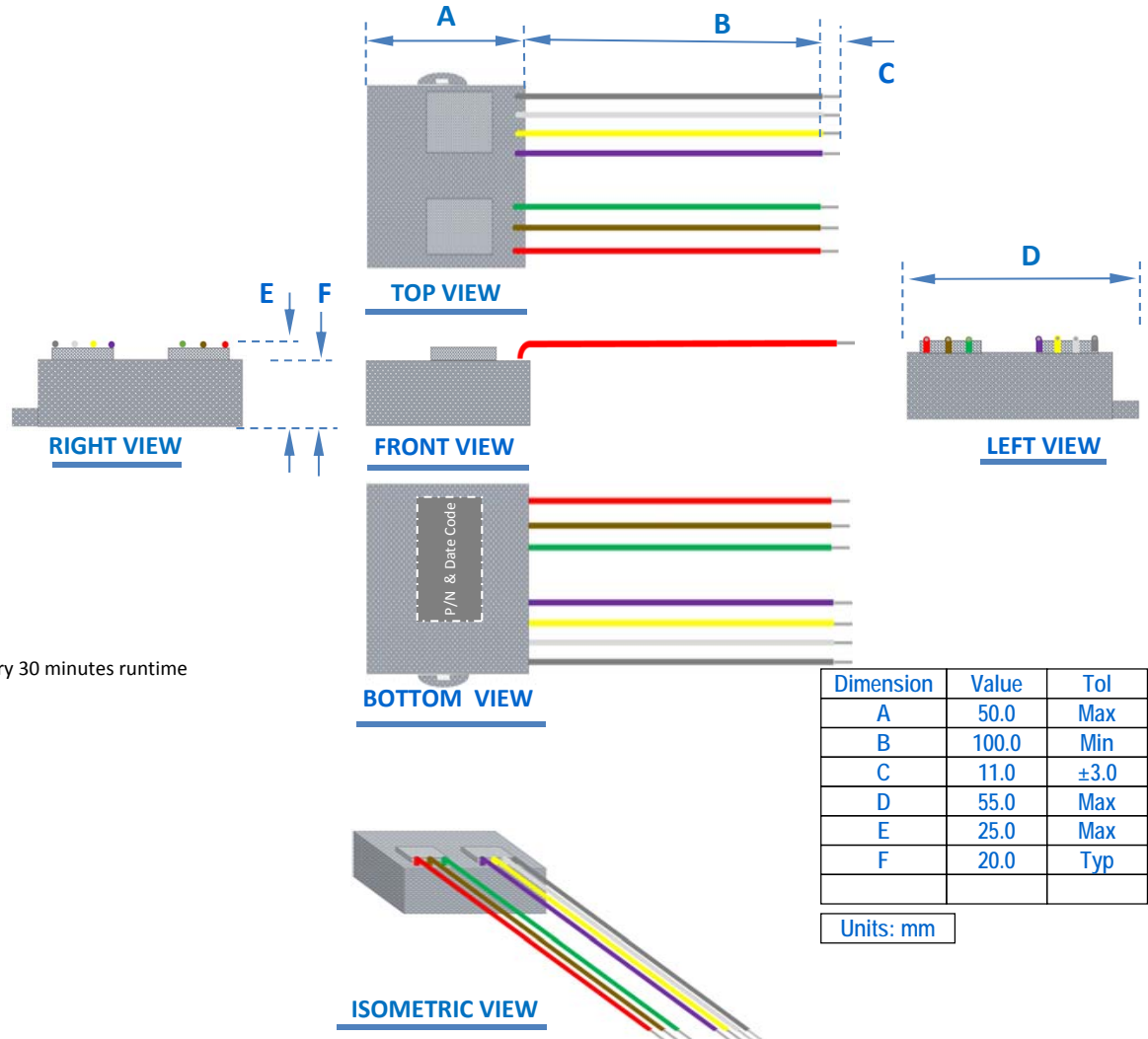
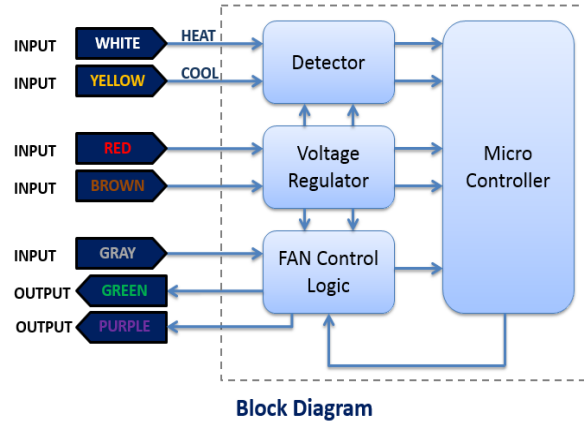

Dimension	Value	Tol
A	50.0	Max
B	100.0	Min
C	11.0	±3.0
D	55.0	Max
E	25.0	Max
F	20.0	Typ

Units: mm

12. Add P/N and Date Code on the bottom of the part
11. Installation instructions available at www.hvac-chip.com
Electric Heating, or Heat Pump and Air Conditioning.
10. It works on most HVAC systems and thermostats for Gas or
9. This device also shuts the compressor OFF for about 3 to 5 minutes every 30 minutes runtime time the unit has been turned ON and turned OFF over previous cycles
8. The extended time of the Fan is set according to the
7. 180 Seconds Maximum
6. 0 Seconds Minimum

EXTENDED TIME OF THE FAN

Purple(Output Compressor relay).
(Output to blower), Gray (Input from thermostat Fan signal)
input Signal), Brown (Common), Red (24 Vac), Green

5. Wire Colors: White (Heat Input Signal), Yellow (Cool

DESCRIPTION OF THE WIRES

4. Operating Temperature -25°C to +85 °C
3. Install only on HVAC Systems with 24Vac in its control section
2. Color: Black
1. Rain Proof (Encasulated with epoxy)

NOTES: UNLESS OTHERWISE SPECIFIED, READ TEXT FROM BOTTOM UP

Revision History

Rev.	ECN	Description	Sign & Date			
			By	Date	CHK	Date
01		RELEASE TO PRODCUTION	JL	2/22/14	JL	2/22/14

UNLESS OTHERWISE SPECIFIED DIMENSIONING AND TOLERANCES PER ANSI Y14.5M ALL DIMENSIONS ARE IN INCHES [MILIMETER] TOLERANCE INCHES: .XXX = ±0.010 .XX = 0.020 ∠ = 0° 30' TOLERANCE METRICS: .XXX = ±0.254 .XX = 0.51 ∠ = 0° 30' ANGLE PROJECTION	Sign	Date	www.hvac-chip.com sales@coilws.com	Coil Winding Specialist, Inc. 353 West Grove Ave. Orange, California 92865		
	Drawn	12/17/13		Title	ENERGY SAVING HVAC CONTROLLER	
	Checked	12/17/13	Engineer	SIZE	DWG. P/N	REV.
	Approved	12/17/13	JL	A	CWS-8THEM-0006D1	01
		12/17/13		Scale	Not to scale	Sheet 1 of 1